

SPECIFICATIONS

6 INCH DRY PRIME

Premier Pump Model 6x6CS2-VP-4045TF280-60 Vacuum Assisted, Engine Driven, Heavy Duty Solids Handling Pump

Pump Specifications:

- Pump size: 6"X 6" AISI 150# flanges standard
- Suction Cover: ASTM A48 class 30 gray iron
- Wear Ring: ASTM A48 class 30 gray iron
- Volute Casing: ASTM A48 class 30 gray iron
- Volute Cleanout: Handhole type, ASTM A48 class 30 gray iron
- Backplate: ASTM A48 class 30 gray iron
- Bracket: ASTM A48 class 30 gray iron
- Mechanical Seal: Tungsten vs. Silicon Carbide seal faces, Viton elastomers, 300 series stainless steel hardware & spring, seal system designed for dry running
- Impeller: Enclosed type, two port, non clog, w/3 inch spherical solids handling capability. ASTM A48 class 30 gray iron
- Bearing Housing: ASTM A48 class 30 gray iron
- Pump-end Bearing: Single row ball – 6313-C3
- Drive-end Bearing: Single row ball – 6313-C3
- Shaft: 1144 Stressproof steel (Other metals available including: 17-4 PH corrosion resistant)
- Lip Seals: CR type, single lip: Bearings, SAE cover - Buna-N, Seal gland – Viton
- Midland 1300 series compressor. Lubricated by engine oil and cooled by engine water
- Separator Spool: Standard steel
- Air/Water chamber: Chamber designed to separate air and water before entering the pump case
- Venturi: Constructed of non-corrosive bronze
- Discharge check valve: Swing type, cast iron w/Buna-N disc (Viton optional)

Optional Equipment and Materials: Stainless Steel, CD4MCU & Ductile Iron

Engine Specification:

- Model: John Deere model 4045TF280 Tier 3
- 80 intermittent horsepower @ 2400 RPM
- Four cylinder, four cycle, water cooled diesel engine
- Governor: Mechanical
- Lubrication: Force Feed
- Air Cleaner: Filter element
- Fuel Tank: 60 US gallons
- Run time: Full load (1800 RPM) ~ 24 hours
- Starter: 12 volt electric



Standard engine features: Safety shutdown switches for low oil pressure and high temperature. Instrument panel with temperature and oil pressure gauge, ampmeter, hourmeter and tachometer. Muffler with rain cap. Engine to pump coupling: SAE3 housing with 10" rubber disc drive.

Standard Skid: Heavy duty fabricated steel frame. Integral fuel tank, lifting bale, lockable fuel tank, and one 1½" clean-out/drain plug

Standard Trailer: Heavy duty fabricated steel frame, integral fuel tank, fenders, lifting bail, lockable fuel cap, 3500# Anti-torsional axle, two (2) front adjustable leveling jacks and two (2) rear adjustable leveling jacks, one 1½" clean-out plug, fuel gauge, adjustable height tongue with easy conversion from ball hitch to Lunette eye

Trailer Options: DOT light package, work lights, special tires & wheels, dual axles, diamond plate fenders, surge brakes, lockable enclosed instrument panel, lockable enclosed engine housing, storage box, hose rack and more

Specifications subject to change without notice

Premier Pump and Power, LLC • PO Box 6423 • Vancouver, WA 98668 • Phone 360.574.4519 • Fax 772.679.5989



PREMIER PUMP & POWER
THE WAVE OF THE FUTURE

Premier Pump and Power, LLC

www.wastewaterpumps.net

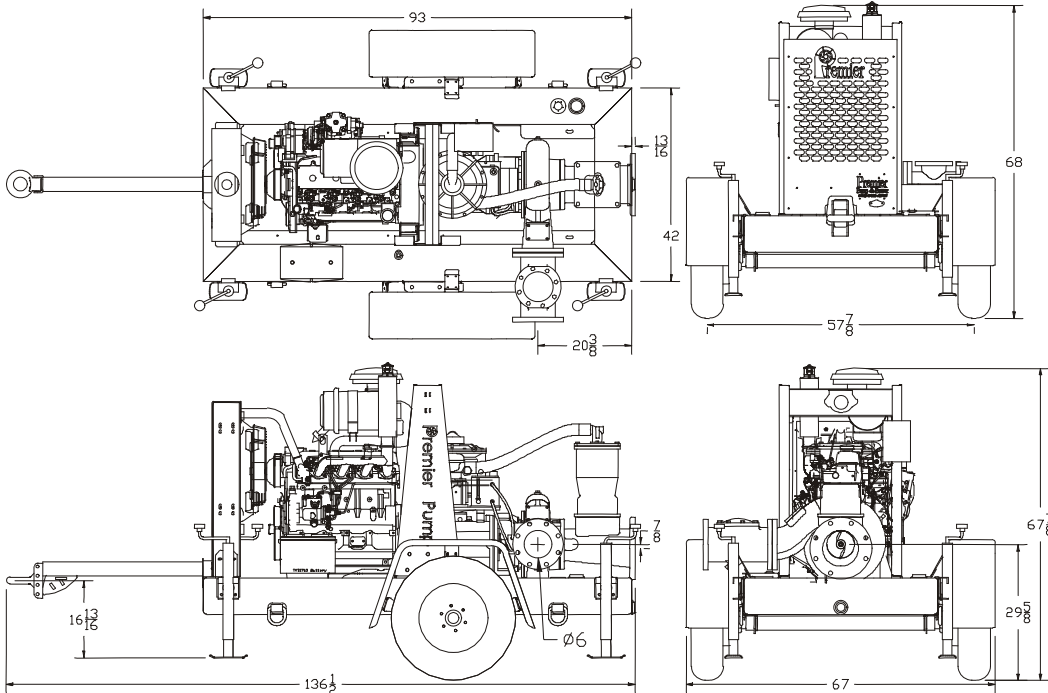
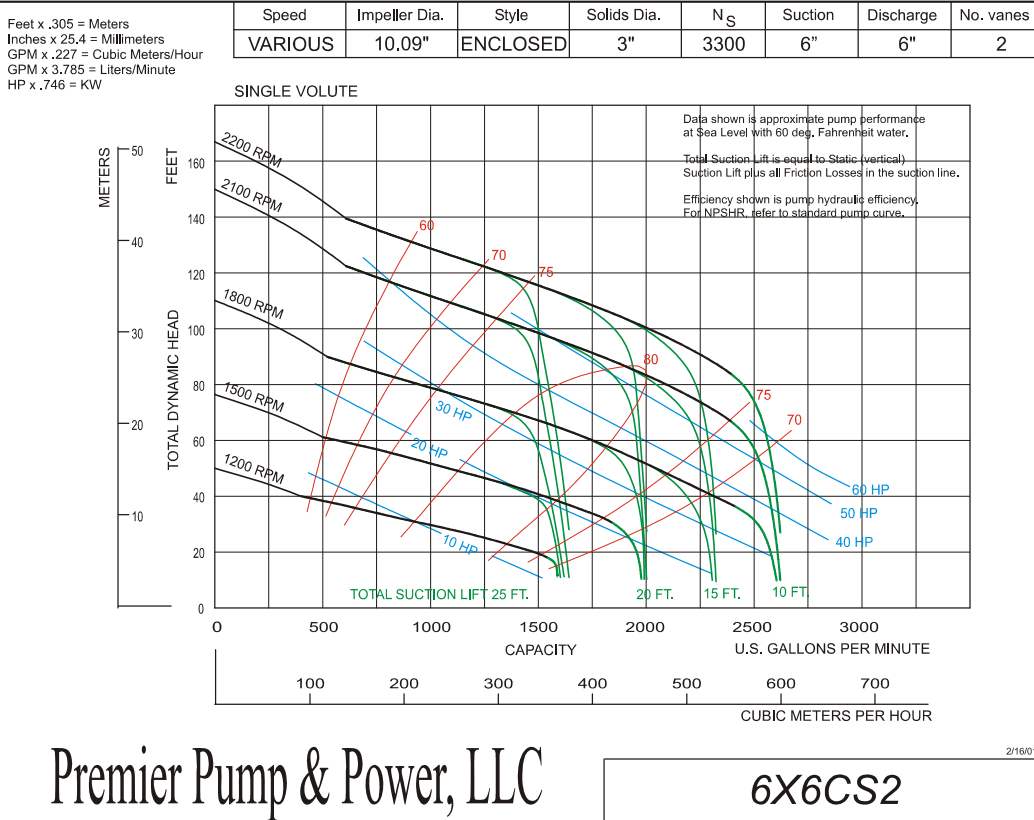

Specifications subject to change without notice

Premier Pump and Power, LLC • PO Box 6423 • Vancouver, WA 98668 • Phone 360.574.4519 • Fax 772.679.5989



JOHN DEERE

ENGINE PERFORMANCE CURVE

Rating: Gross Power

Application: Industrial
Intermittent / Continuous

PowerTech M™ 4.5 L Engine

Model: 4045TF280

80 hp @ 2400 rpm

60 kW @ 2400 rpm

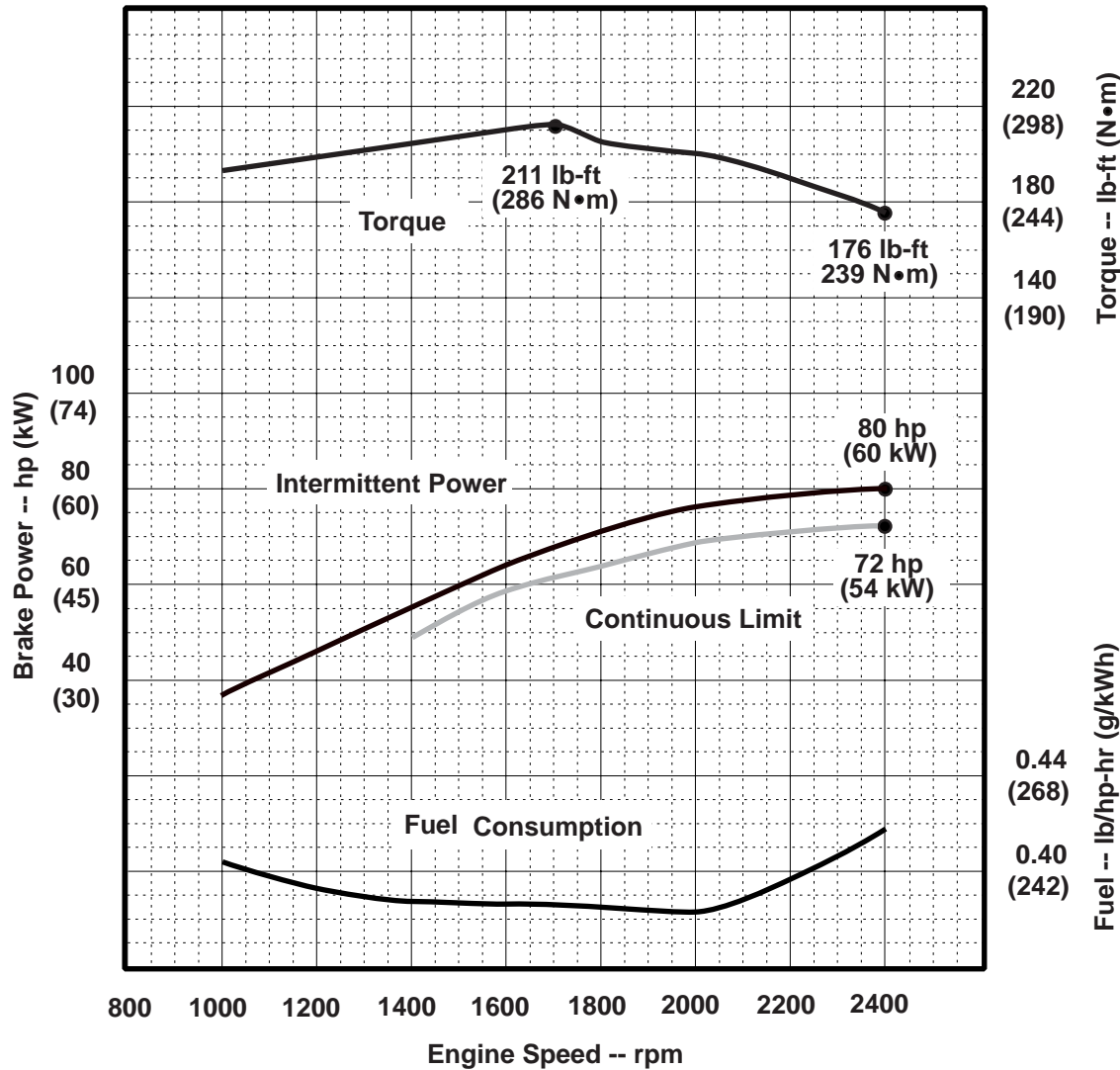

Air Intake Restriction 12 in.H₂O (3 kPa)
 Exhaust Back Pressure 30 in.H₂O (7.5 kPa)

Gross power guaranteed within + or - 5% at SAE J1995 and ISO 3046 conditions:

- 77 °F (25 °C) air inlet temperature
- 29.31 in.Hg (99 kPa) barometer
- 104 °F (40 °C) fuel inlet temperature
- 0.853 fuel specific gravity @ 60 °F (15.5 °C)

Conversion factors:

- Power: kW = hp x 0.746
- Fuel: 1 gal = 7.1 lb, 1 L = 0.85 kg
- Torque: N•m = lb-ft x 1.356

All values are from currently available data and are subject to change without notice.

Notes:

Tier-3 Emission Certifications:

Certified by:

CARB; EPA; EU
 Ref: Engine Emission Label

Vincent...
 08-24-07

* Revised Data

Curve: 4045TF28080_2400..... Sheet 1 of 2
 August 2007

General Data

Model4045TF280
 Number of Cylinders 4
 Bore and Stroke--in. (mm)..... 4.20 x 5.00 (106 x 127)
 Displacement--in.³ (L)275 (4.5)
 Compression Ratio 19.0 : 1
 Valves per Cylinder--Intake/Exhaust 1 / 1
 Firing Order 1-3-4-2
 Combustion System Direct Injection
 Engine Type In-line, 4-Cycle
 Aspiration Turbocharged
 Engine Crankcase Vent System Open
 Maximum Crankcase Pressure--in. H₂O (kPa)2 (0.5)

Physical Data

Length--in. (mm)33.9 (860)
 Width--in. (mm)24.1 (612)
 Height--in. (mm)39.1 (994)
 Weight, dry--lb (kg)872 (396)
 (Includes flywheel housing, flywheel & electrics)
 Center of Gravity Location
 From Rear Face of Block (X-axis)--in. (mm) .10.5 (267)
 Right of Crankshaft (Y-axis)--in. (mm)0.5 (13)
 Above Crankshaft (Z-axis)--in. (mm).....4.3 (109)
 Max. Allow. Static Bending Moment at Rear
 Face of Flywhl Hsg w/ 5-G Load--lb-ft (N•m) ...600 (814)
 Thrust Bearing Load Limit (Forward)--lb (N)900 (4003)

Air System

Maximum Allowable Temp Rise--Ambient Air to
 Engine Inlet--°F (°C)..... 15 (8)
 Maximum Air Intake Restriction
 Dirty Air Cleaner--in. H₂O (kPa)25 (6.25)
 Clean Air Cleaner--in. H₂O (kPa) 12 (3)
 Engine Air Flow--ft³/min (m³/min) [I].....233 (6.6)
 [C]222 (6.3)
 Intake Manifold Pressure--psi (kPa) [I].....10 (76)
 [C]9 (68)
 Recommended Intake Pipe Diameter--in. (mm).....3 (76.2)

Engine Installation Criteria

Cooling System

Engine Heat Rejection--BTU/min (kW) [I].....2277 (40)
 [C].....2049 (36)
 Coolant Flow--gal/min (L/min) 52 (196)
 Thermostat Start to Open--°F (°C)..... 180 (82)
 Thermostat Fully Open--°F (°C).....201 (94)
 Engine Coolant Capacity--qt (L) 9 (8.5)
 Recommended Pressure Cap--psi (kPa)..... 10 (69)
 Maximum Top Tank Temp--°F (°C)221 (105)
 Minimum Coolant Fill Rate--gal/min (L/min) 3 (11)
 Minimum Air-to-Boil Temperature--°F (°C)..... 117 (47)
 Min. Pump Inlet Pressure--psi (kPa)..... 4.4 (30)

Electrical System

12 Volt 24 Volt

Rec'md. Battery Capacity (CCA)--amp 640 570
 Max. Allow. Starting Circuit Resist.--Ohm 0.0012..... 0.002
 Starter Rolling Current
 At 32 °F (0 °C)--amp 780 600
 At -22 °F (-30 °C)--amp 1000 700

Exhaust System

Exhaust Flow--ft³/min (m³/min) [I] 581 (16.4)
 [C]..... 544 (15.4)
 Exhaust Temperature--°F (°C) [I] 934 (501)
 [C]..... 892 (478)
 Max. Allowable Back Pressure--in. H₂O (kPa) 30 (7.5)
 Rec'd. Exhaust Pipe Diameter--in. (mm) 4.0 (101.6)

Fuel System

Fuel Injection Pump Stanadyne DB4
 Governor Regulation..... 7-10 %
 Governor Type Mechanical
 Total Fuel Flow--lb/hr (kg/hr) [I] 155 (70)
 Fuel Consumption--lb/hr (kg/hr) [I]..... 34 (15.7)
 [C] 32 (14.3)
 Maximum Fuel Transfer Pump Suction--ft (m) fuel... 3 (0.9)
 Maximum Fuel Inlet Temp.--°F (°C)212 (100)
 Fuel Filter Micron Size @ 98% Efficiency 2

Lubrication System

Oil Pressure at Rated Speed--psi (kPa) 50 (345)
 Oil Pressure at Low Idle--psi (kPa) 15 (105)
 In Pan Oil Temperature--°F (°C) 244 (118)
 Engine Angularity Limits any direction--degrees
 Intermittent..... 45
 Continuous..... 20

Performance Data

Rated Power--hp (kW) [I]..... 80 (60)
 [C] 72 (54)
 Rated Speed--rpm 2400
 Peak Torque--lb-ft (N•m) [I]..... 211 (286)
 [C] 190 (257)
 Peak Torque Speed--rpm 1700
 Low Idle Speed--rpm 850
 BMEP--psi (kPa) [I] 96 (663)
 [C] 87 (597)
 Friction Power @ Rated Speed--hp (kW) 28 (21)
 Altitude Capability -- ft (m) 10,000 (3050)
 Ratio--Air : Fuel [I] 28.7 : 1
 [C] 30.4 : 1
 Smoke @ Rated Speed--Bosch No. [I]..... 1.0
 [C] 0.9
 Noise--dB(A) @ 1 m [I] NA
 [C] NA

Engine Speed rpm	Contin. Limit hp(kW)	Intermit. Power hp(kW)	Intermit. Torque lb-ft(N•m)	BSFC lb/hp-hr (g/kWh)
2400	72 (54)	80 (60)	176 (239)	0.429 (261)
2200	71 (53)	79 (59)	190 (258)	0.406 (247)
2000	69 (51)	76 (57)	200 (271)	0.400 (243)
1800	64 (48)	71 (53)	206 (279)	0.398 (242)
1700	61 (46)	68 (51)	211 (286)	0.395 (240)
1600	58 (43)	64 (48)	210 (285)	0.391 (238)
1400	49 (37)	55 (41)	205 (278)	0.387 (235)
1200	-----	46 (34)	199 (270)	0.395 (240)
1000	-----	37 (27)	192 (260)	0.401 (244)

All values at rated speed and power with standard options unless otherwise noted.

* Revised Data
 Curve: 4045TF28080_2400 Sheet 2 of 2
 August 2007