

SPECIFICATIONS

6 INCH HIGH PRESSURE DRY PRIME

Premier Pump Model 6x6CSH-VP-4045HF485-120

Vacuum Assisted, Engine Driven, Heavy Duty Solids Handling Pump

Pump Specifications:

- Pump size: 6"X 6" AISI 150# flanges standard
- Suction Cover: ASTM A48 class 30 gray iron
- Wear Ring: ASTM A48 class 30 gray iron
- Volute Casing: ASTM A48 class 30 gray iron
- Volute Cleanout: Handhole type, ASTM A48 class 30 gray iron
- Backplate: ASTM A48 class 30 gray iron
- Bracket: ASTM A48 class 30 gray iron
- Mechanical Seal: Tungsten vs. Silicon Carbide seal faces, Viton elastomers, 300 series stainless steel hardware & spring, seal system designed for dry running
- Impeller: Enclosed type, two port, non clog, w/3 inch spherical solids handling capability. ASTM A48 class 30 gray iron
- Bearing Housing: ASTM A48 class 30 gray iron
- Pump-end Bearing: Single row ball – 6313-C3
- Drive-end Bearing: Single row ball – 6313-C3
- Shaft: 1144 Stressproof steel (Other metals available including: 17-4 PH corrosion resistant)
- Lip Seals: CR type, single lip: Bearings, SAE cover - Buna-N, Seal gland – Viton
- Midland 1300 series compressor. Lubricated by engine oil and cooled by engine water
- Separator Spool: Standard steel
- Air/Water chamber: Chamber designed to separate air and water before entering the pump case
- Venturi: Constructed of non-corrosive bronze
- Discharge check valve: Swing type, cast iron w/Buna-N disc (Viton optional)

Optional Equipment and Materials: Stainless Steel, CD4MCU & Ductile Iron

Engine Specification:

- Model: John Deere model 4045HF485
- 173 intermittent horsepower @ 2400 RPM
- Four cylinder, four cycle, water cooled diesel engine
- Governor: Mechanical
- Lubrication: Force Feed
- Air Cleaner: Filter element
- Fuel Tank: 120 US gallons
- Run time: Full load (1800 RPM) > 16 hours
- Starter: 12 volt electric



Standard engine features: Safety shutdown switches for low oil pressure and high temperature. Instrument panel with temperature and oil pressure gauge, ampmeter, hourmeter and tachometer. Muffler with rain cap. Engine to pump coupling: SAE3 housing with 10" rubber disc drive.

Standard Skid: Heavy duty fabricated steel frame. Integral fuel tank, lifting bale, lockable fuel tank, and one 1½" clean-out/drain plug

Standard Trailer: Heavy duty fabricated steel frame, integral fuel tank, fenders, lifting bail, lockable fuel cap, 6000# Anti-torsional axle, two (2) front adjustable leveling jacks and two (2) rear adjustable leveling jacks, one 1½" clean-out plug, fuel gauge, adjustable height tongue with easy conversion from ball hitch to Lunette eye

Trailer Options: DOT light package, work lights, special tires & wheels, dual axles, diamond plate fenders, surge brakes, lockable enclosed instrument panel, lockable enclosed engine housing, storage box, hose rack and more

Specifications subject to change without notice

Premier Pump and Power, LLC • PO Box 6423 • Vancouver, WA 98668 • Phone 360.574.4519 • Fax 772.679.5989



PREMIER PUMP & POWER
THE WAVE OF THE FUTURE

Premier Pump and Power, LLC

www.wastewaterpumps.net

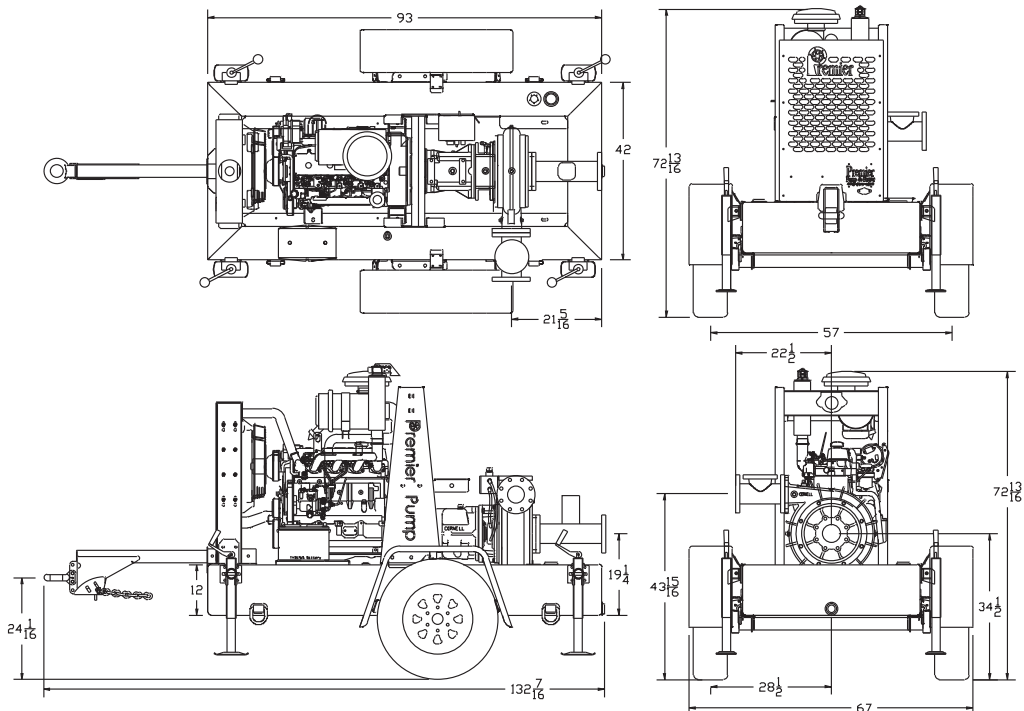
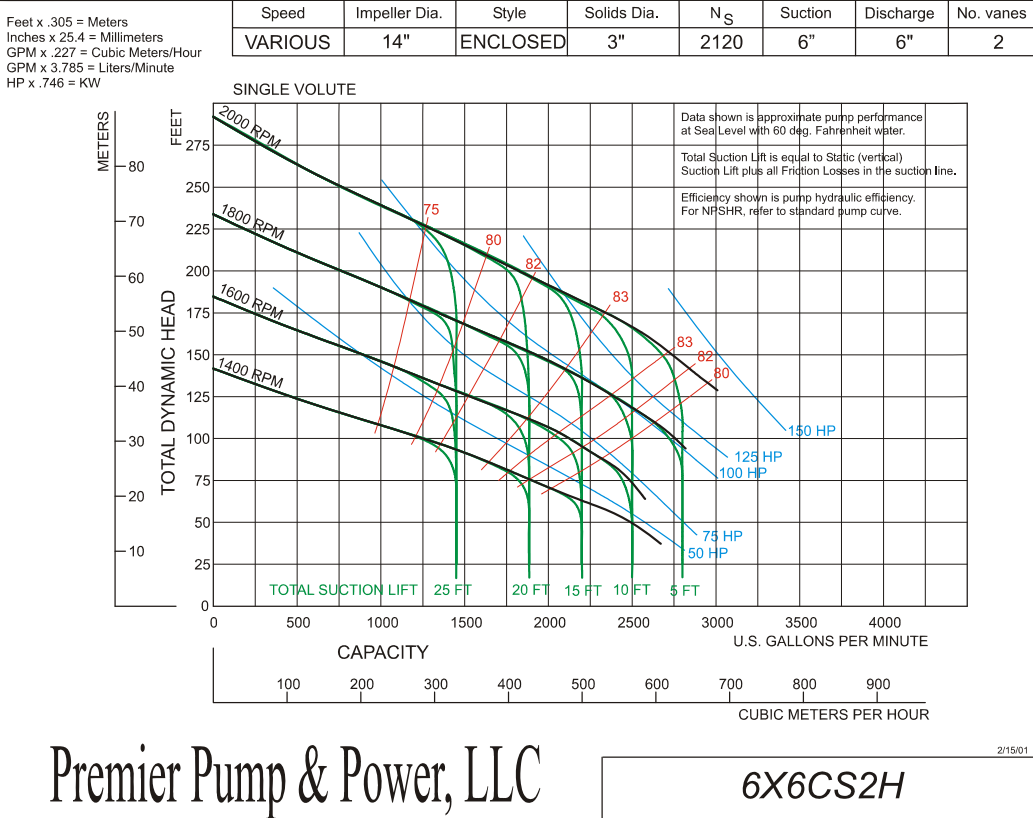

Specifications subject to change without notice

Premier Pump and Power, LLC • PO Box 6423 • Vancouver, WA 98668 • Phone 360.574.4519 • Fax 772.679.5989



JOHN DEERE

ENGINE PERFORMANCE CURVE

Rating: Gross Power
 Application: Industrial - Intermittent
 Power Bulge - 0%
 Torque Rise - 26%

PowerTech Plus™ 4.5 L Engine

Model: **4045HF485**

JD Electronic Control

173 hp @ 2400 rpm

129 kW @ 2400 rpm

[See Option Code Table]

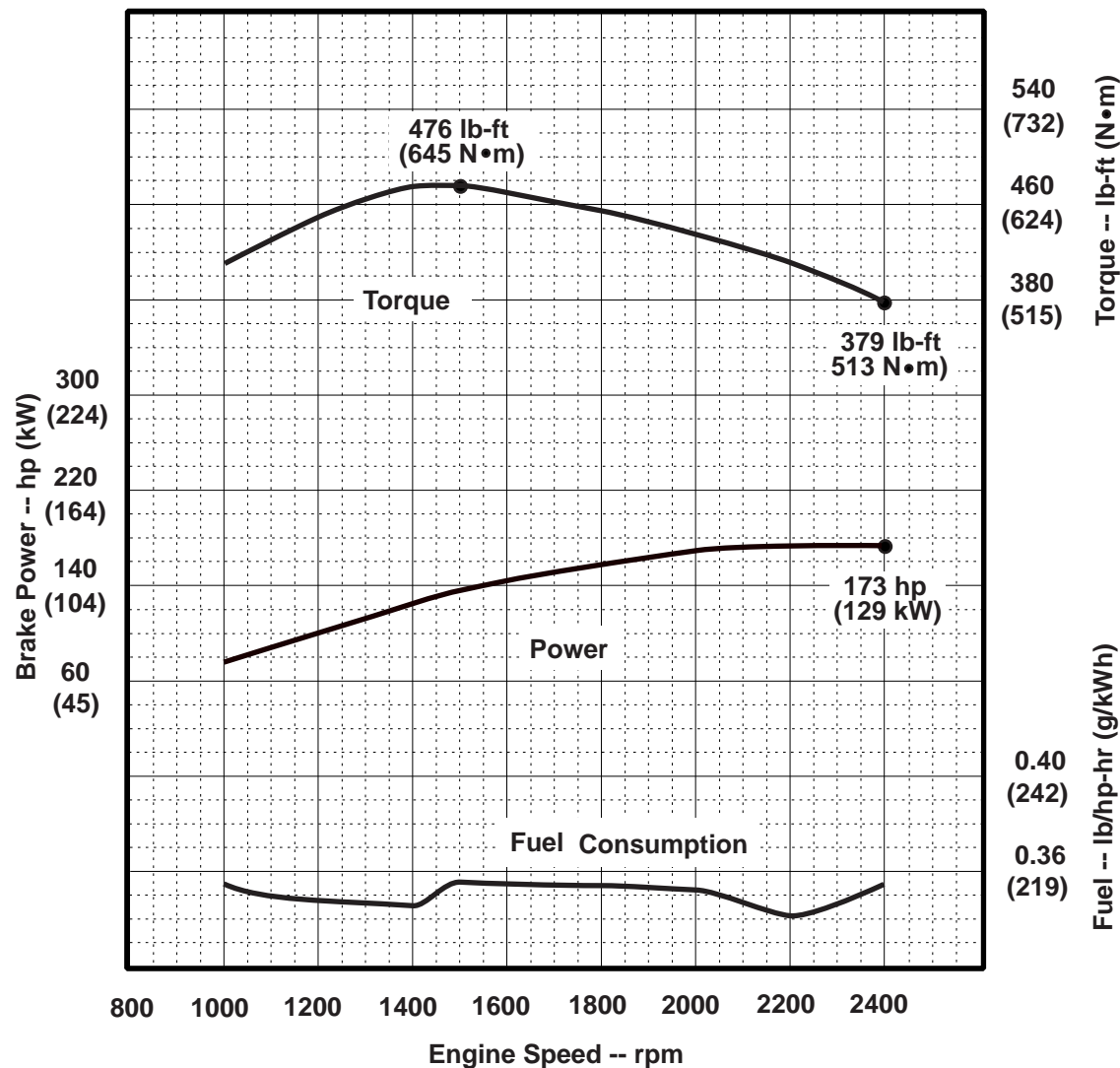

STANDARD CONDITIONS

Air Intake Restriction 12 in.H₂O (3 kPa)
 Exhaust Back Pressure 30 in.H₂O (7.5 kPa)

Gross power guaranteed within + or - 5% at SAE J1995 and ISO 3046 conditions:
 77 °F (25 °C) air inlet temperature
 29.31 in.Hg (99 kPa) barometer
 104 °F (40 °C) fuel inlet temperature
 0.853 fuel specific gravity @ 60 °F (15.5 °C)

Conversion factors:
 Power: kW = hp x 0.746
 Fuel: 1 gal = 7.1 lb, 1 L = 0.85 kg
 Torque: N·m = lb-ft x 1.356

All values are from currently available data and are subject to change without notice.

Notes:

Tier-3 Emission Certifications:	Certified by:
CARB; EPA; EU Ref: Engine Emission Label	<i>Brian L. Carlson</i> 11 DEC 06

* Revised Data
 Curve: 4045HF485173_2400_0_26 Sheet 1 of 2
 December 2006

Engine Installation Criteria

General Data

Model 4045HF485
 Number of Cylinders 4
 Bore and Stroke--in. (mm)..... 4.19 (106) x 5.00 (127)
 Displacement--in.³ (L)275 (4.5)
 Compression Ratio 17.0 : 1
 Valves per Cylinder--Intake/Exhaust 2 / 2
 Firing Order..... 1-3-4-2
 Combustion System..... Unit Injection
 Engine Type In-line, 4-Cycle
 Aspiration Turbocharged
 Charge Air Cooling System..... Air-to-Air
 Engine Crankcase Vent System Open

Physical Data

Length--in. (mm)34.1 (867)
 Width--in. (mm)26.8 (680)
 Height--in. (mm)41.5 (1055)
 Weight, dry--lb (kg)1083 (491)
 (Includes flywheel housing, flywheel & electrics)
 Center of Gravity Location
 From Rear Face of Block(X-axis)--in.(mm).....9.8 (249)
 Right of Crankshaft (Y-axis)--in. (mm).....2.2 (55)
 Above Crankshaft (Z-axis)--in. (mm)5.7 (145)
 Maximum Allowable Static Bending Moment at Rear Face
 of Flywhl Hsg w/ 5-G Load--lb-ft (N•m)600 (814)
 Thrust Bearing Load Limit --lb (N) Forward Rearward
 Intermittent.....899 (4000).....450 (2000)
 Continuous495 (2200).....225 (1000)
 Max. Front of Crank. Torsional Vibration--DDA.....0.25
 Max. Continuous Damper Temp--°F (°C)180 (82)

Electrical System

12 Volt 24 Volt

Min. Battery Capacity (CCA)--amp..... 800 570
 Max. Allow. Starting Circuit Resist.--Ohm 0.0012 0.002
 Starter Rolling Current
 At 32 °F (0 °C)--amp 920 600
 At -22 °F (-30 °C)--amp 1300 700
 Min. Voltage at ECU during Cranking--volts..... 6 10
 Maximum ECU Temperature--°F (°C)221 (105)
 Max. VTG Actuator Surface Temp.--°F (°C)356 (180)
 Maximum Harness Temperature--°F (°C)248 (120)

Air System

Maximum Allowable Temp Rise--Ambient Air to
 Engine Inlet--°F (°C)15 (8)
 Maximum Air Intake Restriction:
 Dirty Air Cleaner--in. H₂O (kPa).....25 (6.25)
 Clean Air Cleaner--in. H₂O (kPa).....15 (3.75)
 Engine Air Flow--ft³/min (m³/min)402 (11.4)
 Air Cleaner Efficiency--%99.9

Charge Air Cooling System

Air/Air Exch'r. Heat Rej.--Btu/min(kW) 1719 (30)
 Compressor Discharge Temp.(Rated)
 @ 77 °F (25°C) Ambient Air--°F (°C).....421 (216)
 Compressor Discharge Temp.(Max.)--°F (°C)
 @ any Ambient--°F (°C) 500 (260)*
 Max. Pressure Drop, thru CAC--in.H₂O (kPa) 52 (13)
 Min. Pressure Drop, thru CAC--in.H₂O (kPa) 20 (5)
 Intake Manifold Pressure--psi (kPa) 25 (175)
 Max CAC Out Temp @ 77°F (25°C) Amb.--°F (°C) 126(52)
 Min CAC Out Temp @ 77°F (25°C) Amb.--°F (°C) 119 (49)
 Max CAC Out Temp @ any Ambient--°F (°C) 190 (88)

Cooling System

Engine Heat Rejection--BTU/min (kW) 4024 (71)
 Coolant Flow--gal/min (L/min)..... 87 (330)
 Thermostat Start to Open--°F (°C)..... 180 (82)
 Thermostat Fully Open--°F (°C).....203 (95)
 Engine Coolant Capacity--qt (L) 9 (8.5)
 Minimum Pressure Cap--psi (kPa)..... 14.5 (100)
 Maximum Top Tank Temp--°F (°C) 230 (110)
 Minimum Coolant Fill Rate--gal/min (L/min) 3 (11)
 Minimum Air-to-Boil Temperature--°F (°C)..... 117 (47)
 Minimum Pump Inlet Pressure--psi (kPa) 4.4 (30)

Exhaust System

Exhaust Flow--ft³/min (m³/min)..... 884 (25)
 Exhaust Temperature--°F (°C).....768 (409)
 Max. Exhaust Restriction--in. H₂O (kPa) 30 (7.5)
 Min. Exhaust Restriction---in. H₂O (kPa)..... 12 (3)
 Max. Bend. Moment on Turbo Out.--lb-ft (N•m) 5.2 (7)
 Max. Shear on Turbo Outlet--lb (kg) 24 (11)

Fuel System

ECU Description L14 Controller*
 Fuel Injection Pump Denso HP3
 Governor Type.....Electronic
 Total Fuel Flow--lb/hr (kg/hr) 148 (67.0)
 Fuel Consumption--lb/hr (kg/hr) 62 (28)
 Max. Fuel Inlet Temperature--°F (°C) 176 (80)
 Fuel Temp. Rise, Inlet to Return--°F (°C) 92 (51)
 Max. Fuel Inlet Restriction--in. H₂O (kPa) 80 (20)
 Max. Fuel Inlet Pressure--in. H₂O (kPa) NA (NA)
 Max. Fuel Return Pressure--in. H₂O (kPa) 80 (20)

Lubrication System

Oil Pressure at Rated Speed--psi (kPa) 58 (400)
 Oil Pressure at Low Idle--psi (kPa) 15 (105)
 Max. Oil Carryover in Blow-by--lb/hr (g/hr) 0.002 (1.0)
 Max. Airflow in Blow-by--gal/min (l/min)..... 26 (100)
 Max. Crankcase Pressure--in. H₂O (kPa)..... 2 (0.5)

Performance Data

Rated Power--hp (kW) 173 (129)
 Rated Speed--rpm 2400
 Breakaway Speed--rpm 2470
 Fast Idle Speed--rpm 2600
 Peak Torque--lb-ft (N•m)..... 476 (645)
 Peak Torque Speed--rpm 1500
 Low Idle Speed--rpm 800
 BMEP--psi (kPa).....208 (1433)
 Friction Power @ Rated Speed--hp (kW) 17 (13)
 Altitude Capability--ft (m) 10,000 (3050)
 Ratio--Air : Fuel 27 : 1
 Smoke @ Rated Speed--Bosch No.<1
 Noise--dB(A) @ 1 m 90.3
 Power Bulge--% 0
 Power Bulge Speed--rpm NA
 Torque Rise--% 26

Engine Speed rpm	Power hp (kW)	Torque lb-ft (N•m)	BSFC lb/hp-hr (g/kWh)
2400	173 (129)	379 (513)	0.355 (216)
2200	173 (129)	413 (559)	0.341 (208)
2000	167 (125)	439 (595)	0.351 (214)
1800	156 (116)	454 (616)	0.353 (215)
1600	143 (107)	470 (637)	0.353 (215)
1500	135 (101)	476 (645)	0.356 (217)
1400	127 (95)	476 (645)	0.346 (211)
1200	103 (77)	450 (611)	0.348 (212)
1000	79 (59)	413 (559)	0.355 (216)

All values at rated speed and power with standard options unless otherwise noted.

* Revised Data
 Curve: 4045HF485173_2400_0_26 Sheet 2 of 2
 December 2006