



a premier pump product

SPECIFICATION SHEET FOR MODEL 4" Trailer Mounted Chopper Pump

VACUUM ASSISTED, HEAVY DUTY SOLIDS
HANDLING PUMP

PUMP SPECIFICATIONS

Size	6" x 4" ANSI 125# flanges ASTM
Impeller/Cutter Bar	Cast Steel, heat treated to minimum Rockwell C 60. Impeller dynamically balanced
Mechanical Seal	Cartridge type with tungsten carbide faces
Thrust Bearings	Back-to-back angular contact ball type, grease lubricated
Radial Bearings	Ball type, grease lubricated
Casing/Back Pull-Out Plate	Ductile Cast Iron. Back pull-out design shall incorporate adjusting sleeves for external adjustment of impeller-to-cutter bar clearance
Shaft	Heat treated steel
Elastomers	Buna N
Discharge check valve	Swing type, ductile iron w/Buna-N disc

PRIMING

Priming System	50 CFM diaphragm vacuum pump
Separator Spool	Standard steel
Air/Water Chamber	Chamber designed to separate air and water before entering the pump case



ENGINE SPECIFICATIONS

Model	Yanmar Model 3TNV88 final Tier 4
Horsepower	25 intermittent horsepower @ 2500 RPM three cylinder, four cycle, water cooled diesel engine
Governor	Mechanical
Fuel Consumption	1.6 Gallons Per Hour @ Max RPM
Safety Shut Down	Low Oil Pressure, High Temperature
Instrument Panel	Lofa CP50 auto start control panel

STANDARD TRAILER

Frame	Heavy duty, powder coated fabricated steel frame with lifting bale
Fuel Tank	65 gallon HDPE fuel cell
Axle	3500# Torsion Flex
Brakes	Electric with DOT lighting package

ENCLOSURE

Material	14 Gauge solid steel outer shell
Finish	Powder coated
Sound Barrier	1"- 2" Acounstical foam insulation
Access Panels	Hinged, lockable swinging doors for easy access to pump and engine.
Sound Level	Unit not to exceed 70 DBA @ 30'

PERFORMANCE CURVE

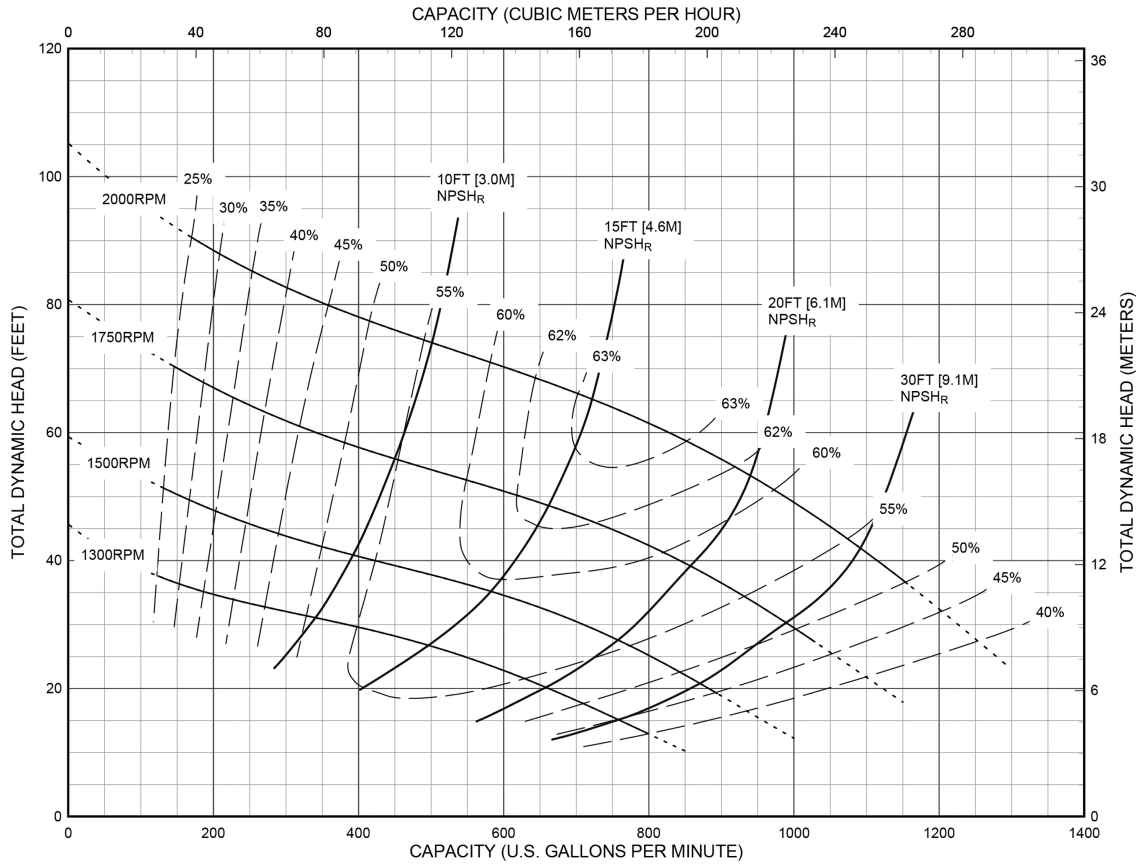

DIMENSIONAL DRAWINGS

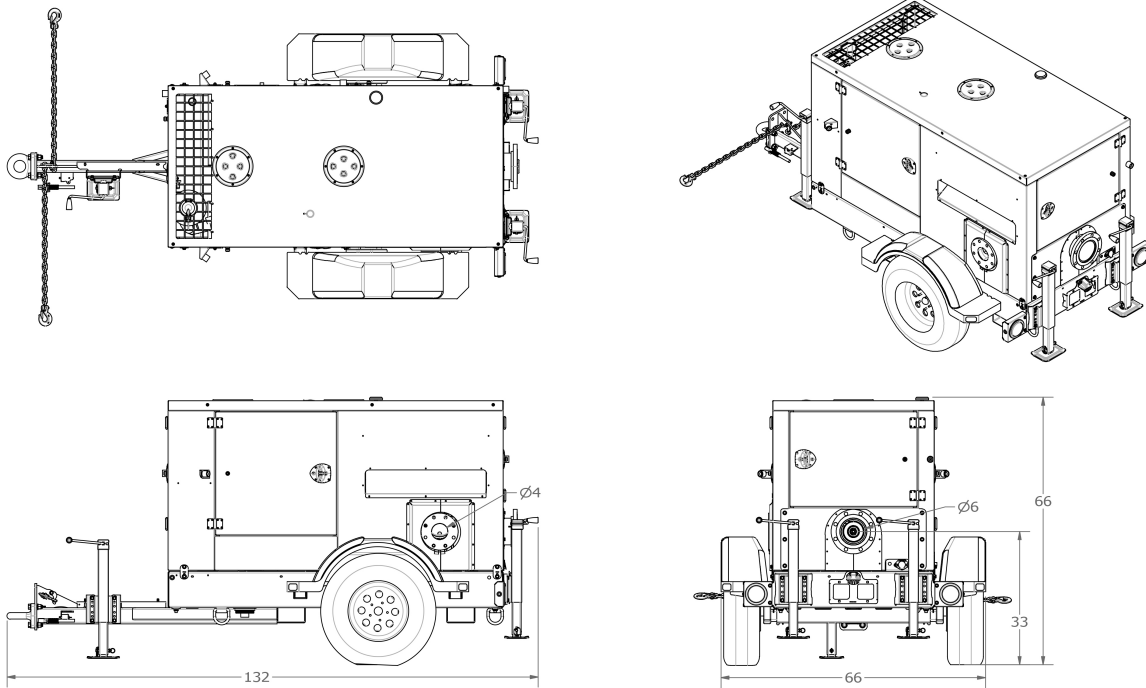

2851.4 lbmass

<small>This document contains proprietary information belonging to Premier Pump and Power, LLC, and such information may not be disclosed to others, reproduced or stored without written authority. Dimensions are subject to change.</small>		STANDARD TOLERANCES: UNLESS OTHERWISE SPECIFIED: DIMENSIONS ARE IN INCHES	PREMIER PUMP & POWER, LLC P.O. Box 6423 Vancouver, Wa. 98668 Ph. # (360) 574-4519 Fax # (360) 576-3967	DATE: 3/5/2018
REV.	DESCRIPTION	DATE	INITIAL	
MATERIAL: ASSEMBLY		PART NUMBER: THE4K6-PP-V1505-T65-SA		

1 of 1